

Convex Array Probe

EUP-CV724

INSTRUCTION MANUAL

Notes for operators and responsible maintenance personnel

- ★ Please read through the Instruction Manual carefully prior to use.
- ★ Keep this Instruction Manual for future reference whenever necessary.

 **Hitachi, Ltd.**
Tokyo , Japan

Q1E-EP1272-6

Manufacturer: Hitachi, Ltd
2-16-1, Higashi-Ueno, Taito-ku, Tokyo, 110-0015, Japan
+81-3-6284-3668
<http://www.hitachi.com/businesses/healthcare/index.html>



European
Representative: Hitachi Medical Systems GmbH
Otto-von-Guericke-Ring 3 D-65205 Wiesbaden, Germany



EU Importer: Hitachi Medical Systems Europe Holding AG
Address: Sumpfstrasse 13 CH-6300 Zug, Switzerland

Local Distributor:

About this manual

This instruction manual shall provide the procedure for inspection, operation, and reprocessing of the EUP-CV724. The manual also contains the general information and the specification of the probe. The probe is usable with the HITACHI ultrasound diagnostic scanner. The operation of the HITACHI ultrasound diagnostic scanner shall be referred to its instruction manual.



To ensure safe operation, it is essential that you fully understand the function, operating and maintenance instructions by thoroughly reading and understanding this manual. Please contact a service support, if you have any questions concerning the operation of the probe.

The following conventions are used throughout the manual to denote information of special emphasis:

- WARNING: "Warning" is used to indicate the presence of a hazard which can cause severe personal injury, death, or substantial property damage if the warning is ignored.
- CAUTION: "Caution" is used to indicate the presence of a hazard which will or can cause minor personal injury or property damage if the caution is ignored.
- NOTICE: "Notice" is used to notify people of installation, operation, or maintenance information which is important, but not hazard related.





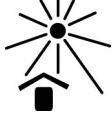



Graphical Symbols for Use in Labeling of Hitachi Ultrasound Probes

Some graphical symbols that are used in labeling of Hitachi Ultrasound Probes are compliant with EN980:2008 standard. Refer to the following table about the meanings of them.

Explanation of Symbol	Symbol	Descriptive Content
Manufacturer Company Name and Address		Hitachi, Ltd 2-16-1, Higashi-Ueno, Taito-ku, Tokyo, 110-0015, Japan +81-3-6284-3668 http://www.hitachi.com/businesses/healthcare/index.html
Authorized Representative in The European Community		Hitachi Medical Systems GmbH Otto-von-Guericke-Ring 3 D-65205 Wiesbaden, Germany
Keep away from Sunlight		Store the probe in a cool, dustproof and dry environment to avoid high temperature, humidity and direct sunlight.

Definition of symbol

The following symbol is also used for HITACHI Ultrasound Probes.

Location	Symbol	Definition
Probe connector		This instrument complies with Directive 93/42/EEC relating to Medical Device and Directive 2011/65/EU relating to RoHS
Probe connector		IPX7 mark See section 1.5.
Probe connector		Type BF APPLIED PART
Probe connector		General warning sign
Probe connector		Warning; dangerous voltage
Probe connector		Caution; Biohazard
Probe connector		Follow the instruction manual to operate this instrument. If not avoided, may result in injury, property damage, or the equipment trouble.
Probe connector		Do not waste the instrument as general waste. Comply with a local regulation.
Probe connector	Rx Only	By prescription only. U.S. Federal Law restricts this device to sale on order of a physician only.

CONTENTS

	Page
1. Introduction	1
1.1 General	1
1.2 Principles of operation	1
1.3 Intended Use	1
1.4 Components List	2
1.5 External View	2
2. Inspection procedure	3
3. Operation Procedure	4
4. Reprocessing Procedure	5
4.1 Point of use (Pre-cleaning)	7
4.2 Containment and transportation	7
4.3 Manual Cleaning and disinfection	7
4.4 Drying	10
4.5 Inspection	10
4.6 Storage	10
5. Daily Inspection (Maintenance)	10
6. Safety Precautions	11
7. Specifications	12
7.1 Probe	12
7.2 Suppliers List	13
8. Disposal of the probe	13

1. Introduction

1.1 General

The model EUP-CV724 is a Convex Array Electronic Scanning type. The probe is capable of acquiring Real-time 3D image by mechanical drive of the acoustic elements.

The acoustic output was measured with operating the Hitachi Ultrasound diagnostic scanner according to IEC60601-2-37. The measured acoustic output is listed in the instruction manual of the Hitachi ultrasound scanner.

The probe is categorized in class IIa according to Directive 93/42/EEC and classified as type BF according to IEC 60601-1.

1.2 Principles of operation

This probe and the ultrasound diagnostic scanner enable image diagnosis using ultrasonic waves. This system operates under the principles described below.

- 1) When an electric pulse signal is applied from the transmitter to the transducer of the probe, the transducer converts electric signals into mechanical vibration energy for emitting pulse-shaped ultrasonic waves into the body part, liquid or other medium contacting the transducer.
- 2) The emitted ultrasonic waves are reflected by boundaries with different acoustic characteristics (acoustic impedance) within the body.
- 3) The transducer is also used to receive reflected ultrasonic waves. The transducer vibrates mechanically due to the received ultrasonic waves and converts mechanical vibrations into electric energy. Electric signals are converted to shades of brightness by brightness modulation to obtain an image.

1.3 Intended Use

The EUP-CV724 is designed for observation and diagnosis, mainly of the following regions.

The EUP-CV724 is operational with only the HITACHI ultrasound scanner.

- Fetal
- Pediatric
- Abdominal
- Small organ

1.4 Components List

The components of the EUP-CV724 are given below.

- 1) EUP-CV724..... 1 piece
- 2) Instruction Manual..... 1 copy
- 3) Correct Backlash CD-ROM..... 1 piece

⚠ CAUTION

The CD-ROM contains the probe's specific parameters to be loaded to the Hitachi ultrasound diagnostic scanner. Hitachi service engineer installs the CD-ROM to the scanner. Store the CD-ROM in a safe place.

1.5 External View

The external view of the EUP-CV724 is given in Fig. 1.

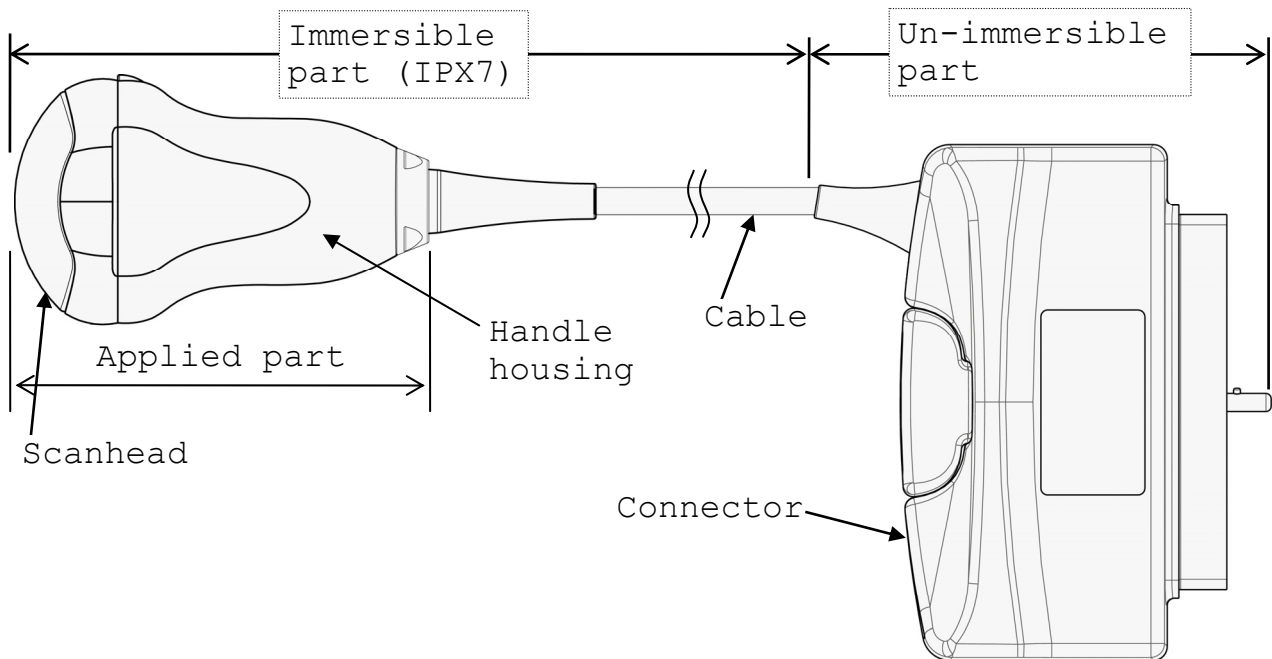

Immersible part:

This part can be immersed in disinfectant solution and also can be cleaned by water.

Un-immersible part:

This part should not be immersed in disinfectant solution and also can not be cleaned by water.

Fig. 1 External View

2. Inspection procedure

Prior to each use, the probe must be carefully inspected as indicated below.

- (1) Visually inspect the surface of the probe head, the housing, the cable and the connector for any crack, scratch or denaturalization.
- (2) Confirm that neither unauthorized devices nor instruments such as unauthorized biopsy attachments are attached to the probe.
- (3) Inspect that the ultrasound diagnostic scanner with which the probe is connected is correctly operating.

If you find an abnormality, do not use the probe, and immediately contact a service support.

3. Operation Procedure

- (1) Confirm that the probe is disinfected.
- (2) Cover the probe with a disposal probe cover to protect the probe. The probe cover should be allergy free material to avoid allergic reaction. Apply acoustic coupling gel inside and outside of the probe cover. Acoustic coupling gel is required as a couplant.
- (3) Connect the probe to the ultrasound diagnostic scanner, operate the scanner, and adjust the image, all according to the instructions given in the operation manual for the ultrasound diagnostic scanner with which the probe is used as connected.
- (4) Confirm the direction of the probe. The relationship between the direction of the probe and the B-mode image is shown in Fig. 2. The right-left orientation mark on the image indicates the direction of the index mark on the probe.
- (5) Perform the reprocessing procedure in accordance with the procedure stated in "4. Reprocessing procedure" every time immediately after completing the ultrasound examination.
- (6) Store the probe in accordance with the storage condition indicated in "8.Specification".

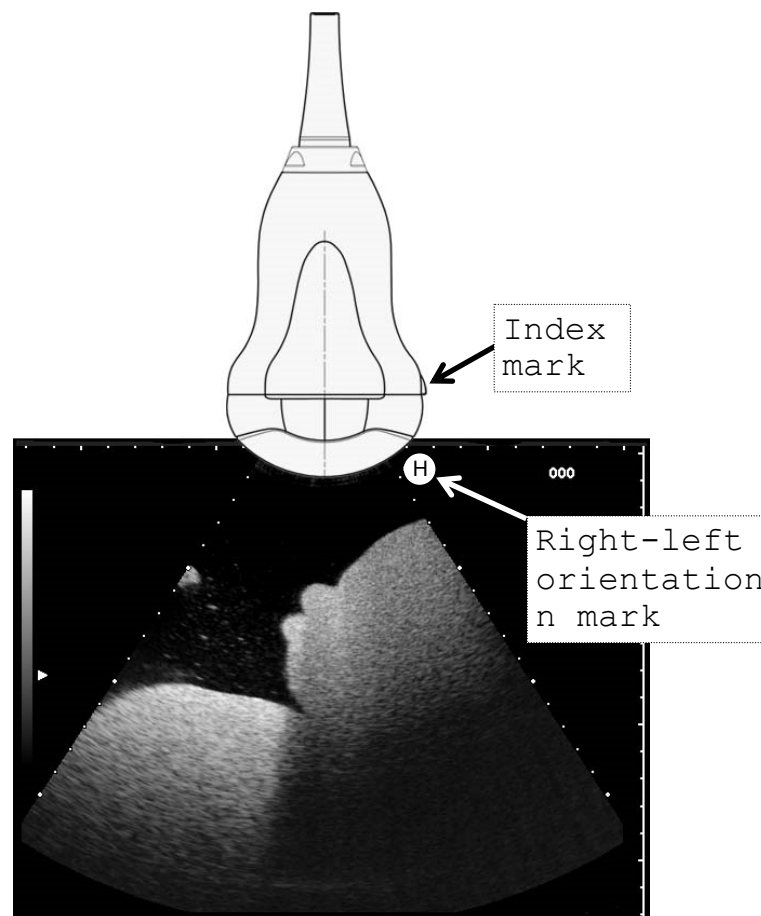

Fig. 2 Relationship between Index Mark and Right-left Orientation Mark

4. Reprocessing Procedure



The probe must be reprocessed after each use. Refer to the reprocessing instruction in this chapter.

WARNINGS	<ul style="list-style-type: none"> - The probe is delivered unsterile. Prior to the first use, reprocess the probe. - Temperature should not exceed 40°C during reprocessing. - Probe connector is not water resistant.
Limitations on reprocessing	The probe is not completely submersible. The immersible part is shown in Fig.1. The un-immersible part should be disinfected by wipe disinfection.
Transportation before using	The probe should be packed in a sterile pouch or container to transport from Central Sterile Supply Department (CSSD) to an operating room. Be careful not to damage the sterile pouch or container during transportation.

Levels of reprocessing requirements:

Depending on the application of the product and with regard to risk evaluation, the user has to classify the medical device according to the current Medical Device Directive for processing of medical devices as uncritical, semi-critical or critical. Supporting information concerning this topic is listed in the table below. The user is responsible for correct classification of the medical device.

Classification	Definition	Processing
uncritical	Application part only contacts intact and uninjured skin	Cleaning Disinfection
semicritical	Application part contacts mucosa (intracavitary application)	Cleaning Disinfection (Disinfectant with virucidal effect)
critical	Application part contacts intracorporeal tissue directly (operative application)	Cleaning Disinfection (Disinfectant with virucidal effect - minimum) Sterilization

According to the intended use, EUP-CV724 probe is classified as uncritical.

The flowchart of the reprocessing process of this probe is as follows.

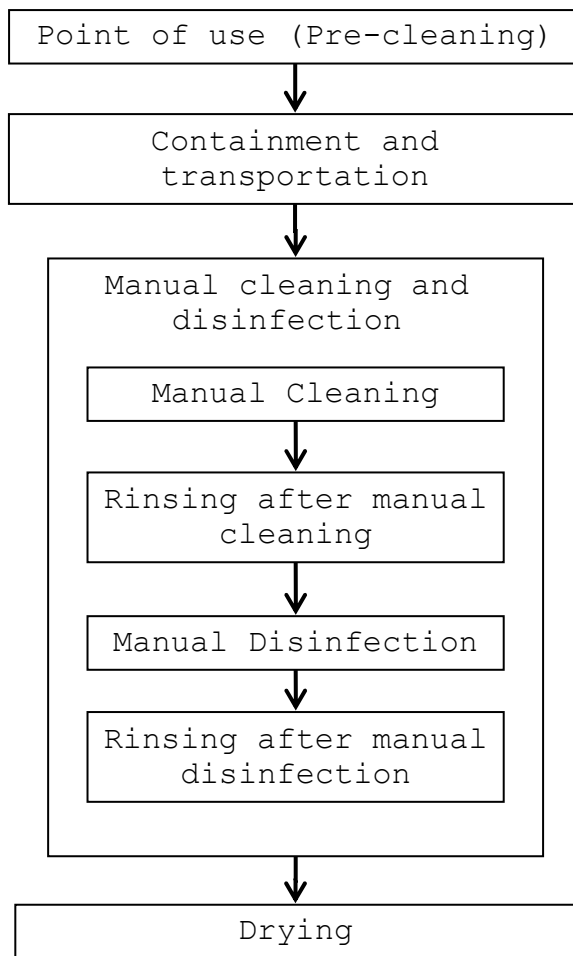

4.1 Point of use (Pre-cleaning)

Pre-cleaning should be done immediately after each use.
The procedure is as follows:

Point of use
(Pre-cleaning)

- 1) Remove the probe cover.
- 2) Clean the probe of all patient's blood or fluid with running tap water until the surface of the probe looks visually clean.
- 3) Wipe the whole surface of the probe with gauze pad and remove superficial visible impurities.

4.2 Containment and transportation

Putting the contaminated equipment into exclusive shock and damage proof container for transportation is recommended. It is recommended that instruments are reprocessed as soon as possible and not later than 4 hours after usage.

Containment and
transportation

4.3 Manual Cleaning and disinfection

Prepare following items before manual cleaning and disinfection:

- a) Detergent: Cidezyme® (Johnson & Johnson, #2258) or another cleaning agent with approved material compatibility for this medical device.
- b) Disinfectant: Cidex® OPA (Johnson & Johnson, # 20391) or another disinfectant with approved material compatibility for this medical device.
- c) Two tanks, one for cleaning and one for disinfection - optional:
1 additional tank for rinsing with deionized/tap water (sufficient size for immersion of the submergible part of the probe at full length)
- d) Soft, fluff free cloth or single use towel
- e) Personal protective equipment (gloves, water repellent protective skirt, face protection mask or protective glasses, see also instructions of the manufacturer for the detergent and the disinfectant)

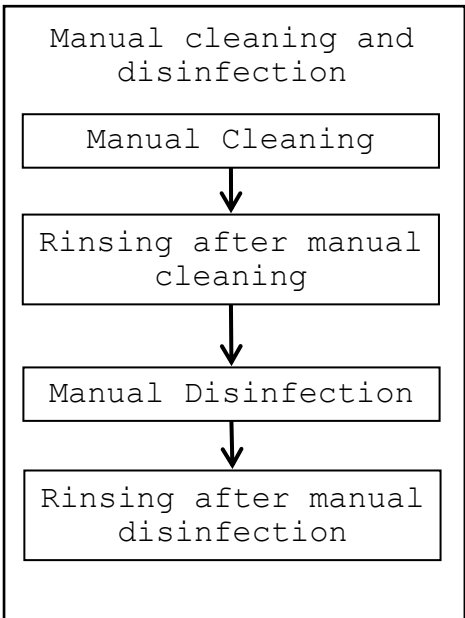

Manual Cleaning:

Prepare the detergent solution in a tank with cold water (please follow the instructions of the detergent manufacturer regarding application, dilution and contact time).

- 1) The temperature of the detergent solution should be between 15-30 °C, concentration is 1.6%. Please note the minimum contact time of the detergent in the manufacturer's instruction. If a differing detergent is used, please also note the approved material compatibility for the medical device.
- 2) Immerse the immersible part of the probe without connector into the diluted detergent solution (see Fig. 3). Wipe the immersible part of the probe under the surface of the detergent solution with a soft cloth to remove all visible soil. Be sure that all grooves of the probe are implemented during the cleaning process.
- 3) The immersible part of the probe should be left in the detergent solution according to the specified contact time of the detergent manufacturer.
- 4) Wipe the un-immersible parts of the probe with a soft cloth dipped with the detergent solution.
- 5) Rinse the probe with running tap water for 1 minute. (alternatively: immerse the immersible part of the probe in a tray filled with deionized water/tap water (see Fig. 3) for 5 min.)
- 6) Visually check the outer surface of the probe for cleanness. If necessary, use magnifying glass for visually check. If there is still soil visible, repeat all above steps.

Manual disinfection:

- 1) Prepare the disinfectant solution in a tank with cold water (please follow the instructions of the disinfectant manufacturer regarding application, concentration, microbiological efficiency, service life and contact time).
- 2) Confirm the concentration of the disinfectant before immersing the probe. Although Cidex® OPA does not need to be diluted, it is recommended to use test strips to verify the concentration. The test strips can indicate whether or not the concentration is above the Minimum Effective Concentration (MEC). Please also note the expiration date of the test stripes. Temperature of disinfectant solution should be minimum 20 °C. The minimum contact time is 5 minutes. If a different disinfectant is used, follow the manufacturer's instructions. Please also consider the material compatibility for the medical device.
- 3) Immerse the immersible part of the probe into the disinfectant (see Fig. 3). Set a clock to insure the recommended contact time which is 5 minutes.
- 4) Rinse the immersible part of the probe with deionized water for 1 minute. (alternatively: immerse the immersible part of the probe in a tray filled with deionized water (see Fig. 3) for 5 min.)
- 5) Visually check the outer surface of the probe for leavings of the disinfectant. If necessary, repeat the rinsing.

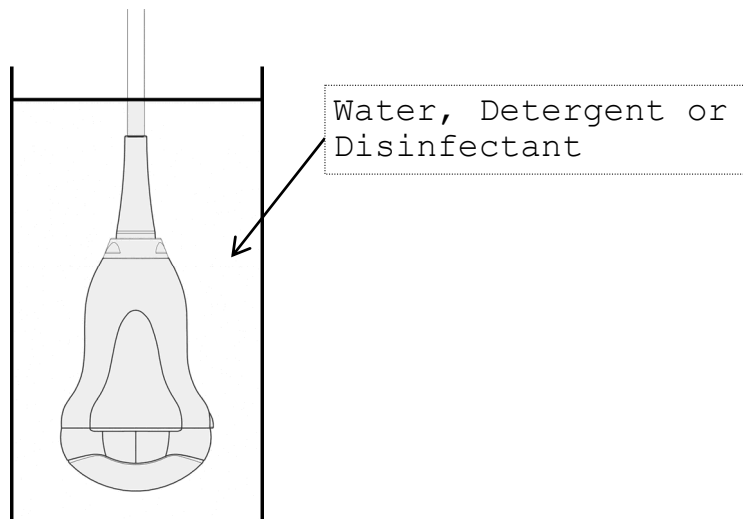

Fig. 3 Immersion of the Probe

4.4 Drying

- 1) Wipe the equipment with a single-use, fluff-free wipe or towel to remove moisture from the surface of the equipment.
- 2) Dry the probe naturally in an ambient temperature between 15-30°C for a minimum of 4 hours. Alternatively the probe can be dried using a drying heater at a temperature of less than 40°C.

4.5 Inspection

Inspect the equipment for any damage such as crack, scratch or deformation. Do not use it if any damage is found.

4.6 Storage



Store the equipment in a cool, dustproof and dark space to avoid high temperature, humidity and direct sunlight. Limitations for the time for sterilized equipment belong to package.

WARNING

- 1) Do not sterilize this probe by pressurizing/ depressurizing sterilization system such as ETO and Plasma system. If you sterilize the probe by these systems, the membrane that seals the oil bursts and the probe will not be functional.
- 2) Do not sterilize this probe by autoclave. If you autoclave the probe, the probe suffers serious damage and will be not functional.

5. Daily Inspection (Maintenance)

- 1) Visually inspect the surface of the probe head, the housing, the cable and the connector for any crack, scratch or denaturalization. If you find damage, do not use the probe, and immediately contact a service support.
- 2) Inspect the functionality of Real-time 3D mode. If you find abnormalities such as abnormal noise, do not use the probe, and contact a service support.

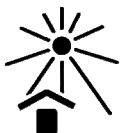

- 3) After the use of the probe, it should be cleaned and disinfected according to chapter 4, then store it in a cool and dark place avoid high temperature and humidity, direct sunlight.

6. Safety Precautions

For safe use of the probe, observe strictly all warnings and cautions listed below.

WARNING

- 1) If you find that the probe head, the housing or cable are cracked or damaged, do not use the probe, and immediately contact a service support.
- 2) For the patients suspected of having latex allergy, do not use latex-containing medical devices. Latex may cause allergic reactions such as itching, rubor, urticaria, swelling, fever, anhelation, wheezing, depression of blood pressure, and shock. If your patients show any of the above-mentioned symptoms, stop using latex-containing medical devices immediately and provide prompt treatment to your patients.

CAUTION

- 1) Start examination with acoustic power low and set the acoustic power as low as possible for ultrasound examination of an early pregnancy. And minimize the ultrasound exposure time.
- 2) Disinfect the probe prior to the initial use since the probe is not delivered disinfected.
- 3) Use only detergents and disinfectants listed in "7.2 Suppliers list".
- 4) Use sterile acoustic coupling gel depending on the diagnostic part. The acoustic coupling gel which is an accessory of Hitachi Ultrasound diagnostic scanner is non-sterile acoustic coupling gel.
- 5) Do not hit or drop the probe because the inside of the probe head is easily broken by mechanical shocks.
- 6) Do not allow liquid to contact/enter the probe connector, as the probe connector is not waterproof.

7. Specifications

7.1 Probe

Type:	EUP-CV724
Acoustic working frequency:	5MHz
Technology:	Convex Array
Dimensions:	See Fig. 4
Weight:	Approx. 1.0kg (including cable and connector)
Scanning angle:	67°
Volume sweep angle:	75°
Probe materials:	Biocompatible allergy free materials
Acoustic output:	Compliance with IEC60601-2-37
Applicable ultrasound diagnostic scanner:	Contact a service support for detail.
Classification:	MDD classification IIa.
Applicable detergent:	Detergent listed in "7.2 Suppliers list"
Applicable disinfectant:	Disinfectant listed in "7.2 Suppliers list"
Operating condition	
Ambient temperature:	+10 to +35°C
Contact surface temperature:	Max. 42°C (Temperature of examinee)
Relative humidity:	30 to 85% (Non condensing)
Storage conditions	
Temperature:	-10 to +55°C
Relative humidity:	10 to 95% (Non condensing)

7.2 Suppliers List

The products listed below are seriously tested and approved for use with the EUP-CV724.

Product name	Manufacturer	Purpose
Alkazyme	ALKAPHARM	Cleaner
Klenzyme	KLENZYME	Cleaner
ENZOL®	Johnson & Johnson	Cleaner
Steranios 2%	Laboratoires ANIOS	High-level Disinfectant
CIDEX®	Johnson & Johnson	High-level Disinfectant
CIDEX® OPA	Johnson & Johnson	High-level Disinfectant
CIDEXPLUS® 28	Johnson & Johnson	High-level Disinfectant

Please contact your local distributor for a current version of the "Disinfectant/Sterilization Method Compatibility for Ultrasound Probe and Accessory List"

⚠ CAUTION

Disinfection with CIDEX® OPA may cause discoloration on the handle housing.

8. Disposal of the probe

Recycle or dispose the equipment properly in compliance with your organizational rules and your local laws.

⚠ CAUTION

Before disposing the equipment, disinfect or take other infection-prevention measures.
Disposal of the equipment without taking the proper preventative measures can lead to infection.

Waste Electrical and Electronic Equipment (WEEE) Directive

The illustration on the right is required by the EU WEEE Directive to appear on all electrical and electronic equipment.

For proper disposal of this product in an EU nation, contact an EU office or agency and observe appropriate local and national regulations and laws.



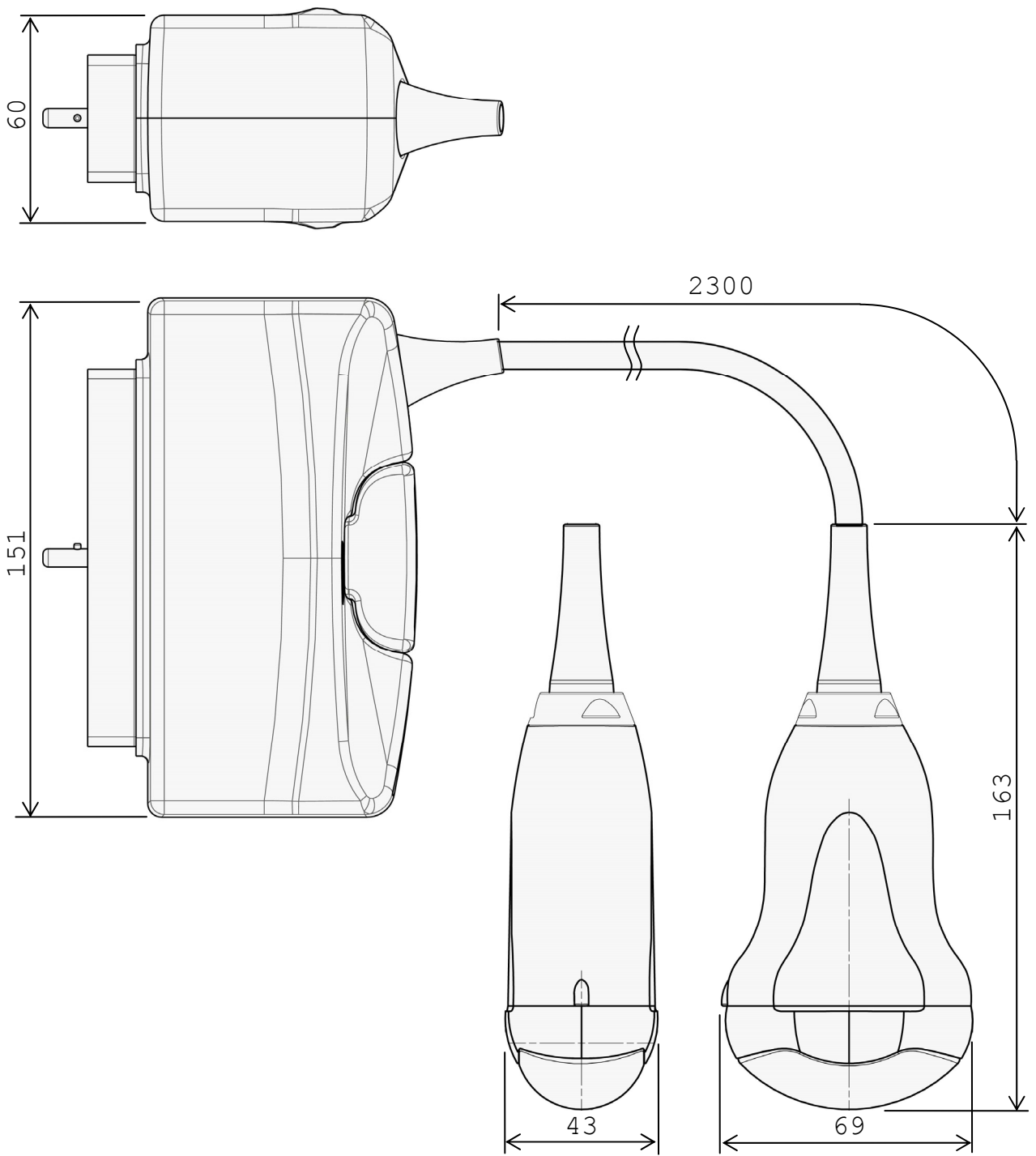

Unit: mm

Fig. 4 Dimension diagram of EUP-CV724

